

# Rumney Models Price List – February 2024

www.rumneymodels.co.uk  
Rumney Models, Bryanstone, Glewstone, Ross-on-Wye, Herefordshire, HR9 6AW  
justinnewitt@gmail.com  
07798 627143

This list replaces all previous lists.  
Items are 4mm scale and are suitable for OO/EM & P4 except where noted.

## New Items

### 4mm Scale

**PFZ.08UICFO** Springs & axleboxes for BR Ferry Opens (Wagon Prints - page 17)  
to diagram 1/055. Oil axleboxes, as built.

### S Scale

**S.61** 17'6" x 10' LNE clasp brake underframe (S Scale - page 23)

## Special Order List

I have decided to do away with the Special Order list as I don't think it's necessary any longer. All the items it contained are now in this list and are available singularly.

## Notes

All items are 4mm scale except where noted.

Some items have been withdrawn from the catalogue or will be withdrawn when stocks have been exhausted. The latter are marked **WSL** (while stocks last) next to the price. Please enquire before ordering. Other items are marked **OOS** (out of stock). These are items that need to be retooled and they may remain out of stock until the opportunity or finances allow.

### 3D Printed Parts

This catalogue contains kits where parts have been produced on my own SLA printer. I have prefixed such items with a P in the catalogue to differentiate them from cast or etched items.

## Index

Milk tank chassis and detailing components	Pages 2 & 3
Wagon underframes	Pages 4 to 6
Wagon detailing	Page 6 & 7
Wagon kits	Pages 8 to 12
Wagon castings	Pages 12 to 15
Wagon prints	Pages 15 to 17
Sprung freight bogies	Pages 17 & 18
Sprung diesel bogies	Page 18
Sprung coach bogie subframes	Page 18
Sprung complete coach bogie kits	Page 18 & 19
Steam loco parts	Pages 19 & 20
Miscellaneous items	Page 20
7mm scale items	Pages 21 & 22
Guage 1 items	Page 22
S Scale items	Page 22 & 23

## 4mm Scale

### Sprung Milk Tank Chassis and Detailing Parts

Designed for use with the David Geen milk tank kits. Etch and spring wire (where appropriate) only.

#### Milk Tanks Chassis

Code	Description	Price per unit
A.01	GWR Standard Milk Tank Chassis <i>20'6" long for the majority of GWR milk tanks.</i>	£11
A.03	LMS Early Milk Tank Chassis <i>For LMS milk tanks built before around 1942.</i>	£11
A.04	LMS Late Milk Tank Chassis <i>For LMS milk tanks built after around 1942.</i>	£11

#### Detailing Parts

A.07	United Dairies SR/GWR Platforms <i>The distinctive platforms fitted to some United Dairies milk tanks.</i>	£7
A.08	SR/GWR Platform Construction Jig <i>Needed to build A.07.</i>	£5
A.09	GWR Detailing <i>GWR lever brakegear, brake shoes/yolks and ladders.</i>	£8
A.10	GWR Alternative Ladders and Walkways <i>Partial platforms, long ladders and planked type walkways.</i>	£8
A.11	LMS Detailing <i>Brake shoes/yolks, planked walkways and alternative ladders.</i>	£8
A.12	Milk Tank Formers <i>For constructing different diameter tanks from brass sheet.</i>	£7

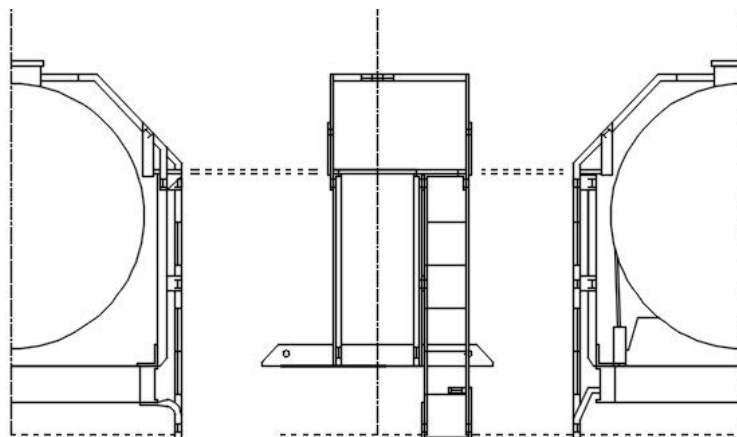

### Milk Tank Plates

Code	Description	Price per unit
A.21A	United Dairies Ltd Milk Tank Plates - Type A <i>Company plates for United Dairies milk tanks.</i>	£2.50
A.21B	United Dairies Ltd Milk Tank Plates - Type B <i>Company plates for United Dairies milk tanks.</i>	£2.50
A.22	Unigate Creameries Milk Tank Plates <i>Company/number plates for Unigate milk tanks.</i>	£2.50
A.23	Express Dairy Milk Tank Plates <i>Company/number plates for Express Dairy milk tanks.</i>	£2.50



- United Dairies Type A



- United Dairies Type B



- Unigate Creameries



- Express Dairy

The United Dairies plates were common in the 1950s but could also be seen through to the 1970s. Type A was much more common than type B. Unigate plates would be found on wagons post 1959. The Unigate plates have the wagon number on the plate. I have done plates for most Unigate diagrams. Please enquire first if you are after plates for specific diagrams. If you aren't worried about diagrams then please say so when ordering. Express Dairy plates include both the company plate and the distinctive round number plate that was attached to the baulks at the tank ends. The numbers were Express Dairy's own fleet numbers and were generally grouped according to who built the milk tank. If you want something specific then please inquire or else you will get a random number. Etched on 0.1mm stainless steel and supplied in pairs and painted.

## Sprung Wagon Chassis

These are comprehensive and include solebars and headstocks. They are designed for use with Parkside Dundas, Red Panda and, in the case of B.06, Chivers Finelines plastic body kits. Etch and spring wire only unless stated otherwise. The following notation for axleguard types is used:

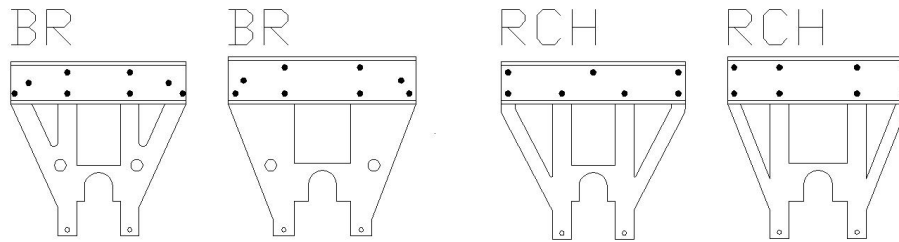

### BR Clasp Brake

Code	Description	Price per unit
<b>B.01</b>	BR 17'6" x 10' BR Clasp Brake Chassis <i>For BR standard vans, Conflats, Shocvans, Shocopens, Lowfits, etc.</i>	£12
<b>B.02</b>	BR 16'6" x 10' BR Clasp Brake Chassis – 26T Iron Ore Tippler <i>For diagram 1/165 iron ore tipplers.</i>	£12
<b>B.03</b>	BR 16'6" x 10' BR Clasp Brake Chassis – 13T Sand Tippler <i>For diagram 1/073 sand tipplers.</i>	£10 <b>WSL</b>
<b>B.04</b>	BR 16'6" x 9' BR Clasp Brake Chassis – 16T Welded Mineral <i>For clasp braked diagram 1/108, 1/114 and 1/117 minerals.</i>	£12
<b>B.05</b>	Additional Parts for Riveted 16T Clasp Braked Minerals <i>For use with B.04 to produce a chassis for the rare clasp braked 1/109s.</i>	£4 <b>WSL</b>
<b>B.06</b>	BR 21'6" x 12' BR Clasp Brake Chassis – 21T Mineral <i>For diagram 1/119 'MDVs' (twin vacuum cylinders/changeover levers)</i>	£14.50
<b>B.08</b>	BR 27' x 15' BR Clasp Brake Chassis – 22T Plate (new builds) <i>For diagram 1/434 Plate wagons built new with the BR clasp brake.</i>	£17.50
<b>B.09</b>	BR 27' x 15' BR Clasp Brake Chassis – 22T Plate (retrofits) <i>For diagram 1/430 and 1/431 Plate wagons retrofitted with the BR clasp brake in the late 50s/early 60s.</i>	£17.50

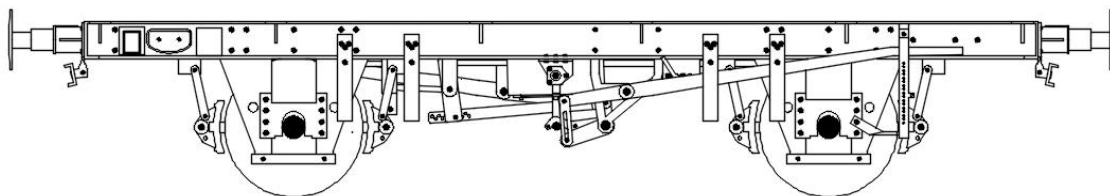

### Morton/Lifting Link Pushrod Brakegear

<b>B.11</b>	BR 17'6" x 10' Morton Brake Chassis <i>For BR standard vans, Conflats, Shocvans, Shocopens, opens, etc.</i>	£12
<b>B.12</b>	RCH 17'6" x 10' Morton Brake Chassis <i>For vans, Conflats, Shocvans, Shocopens, opens, etc.</i>	£12
<b>B.13</b>	BR 16'6" x 9' Morton Brake Chassis – 16T Welded Mineral <i>For the standard welded body, Morton braked 16T mineral wagons.</i>	£9
<b>B.14</b>	Additional Vacuum Braked 16T Mineral Parts <i>Use with B.13 to produce the mid-sixties Morton 4 shoe vacuum braked 16T welded minerals – sufficient for 2 wagons.</i>	£4
<b>B.15</b>	BR 16'6" x 9' Morton Brake Chassis – 16T Riveted Mineral <i>For diagram 1/109 riveted 16T minerals.</i>	£9

Code	Description	Price per unit
<b>B.16</b>	BR 16'6" x 9' Independent Brake Chassis – 16T Welded Mineral <i>For early 16T welded minerals, covers the following diagrams: 1/102 (with BR W-Irons), 1/104, 1/106, 1/108 and 1/111.</i>	£12
<b>B.17</b>	BR 16'6" x 9' Independent Brake Chassis – 16T Riveted Mineral <i>For diagram 1/103 (with BR W-Irons) and 1/105 16T minerals.</i>	£11
<b>B.18</b>	Additional RCH W-Iron Parts for Independent Brake Minerals <i>Use with B.16 or B.17 to produce the earlier RCH W-Iron fitted LMS and LNER minerals. Intended for use with modified Parkside bodies.</i>	£4
<b>B.21</b>	BR 21'6" x 12' Lifting Link Brake Chassis – Welded Minerals <i>For diagram 1/107 21T &amp; diagram 1/115 &amp; 1/118 24½T minerals.</i>	£13.50
<b>B.22</b>	BR 21'6" x 12' Lifting Link Brake Chassis – 21T Riveted Minerals <i>For diagram 1/110 minerals.</i>	£13.50
<b>B.23</b>	RCH 21'6" x 12' Lifting Link Brake Chassis <i>For pre-Nationalisation 20/21T minerals.</i>	£13.50
<b>B.24</b>	BR 16'6" x 10' Independent Brake Chassis – 27T Iron Ore <i>For diagram 1/184 iron ore tippers.</i>	£11
<b>B.25</b>	BR 16'6" x 9' Independent Brake Chassis – 27T Iron Ore <i>For diagram 1/181, 1/182 &amp; 1/183 iron ore tippers.</i>	£11
<b>B.26</b>	BR 16'6" x 9' Morton Brake Chassis – 13T Sand Tippler <i>For diagram 1/071 &amp; 1/072 sand tippers.</i>	Withdrawn
<b>B.27</b>	27' x 15' Lifting Link Brake Chassis – 22T Plate <i>For LMS, LNER and BR unfitted Plate wagons. Note that the kit contains both RCH and BR type axleguards.</i>	£17.50
<b>B.28</b>	BR 21'6" x 12' Lifting Link Brake Chassis – 21T Hopper <i>For diagram 1/146 21T coal hoppers. Includes parts for both fitted and unfitted wagons.</i>	£16
<b>B.29</b>	RCH 21'6" x 12' Morton Brake Chassis – 21T Hopper <i>For mainly private owner 21T coal hoppers.</i>	£14.50
<b>B.30</b>	BR 16' x 9' Morton Brake Chassis - 13T China Clay Open <i>For BR diagram 1/051 china clay opens. Designed for the Ratio kit but can be used with the Bachmann model.</i>	£12.50
<b>B.32</b>	RCH 17'6" x 9' Morton Brake Chassis <i>For LMS &amp; GWR vans, Conflats, opens, etc.</i>	£14.50
<b>B.34</b>	BR 21'6" x 12' Lifting Link Brake Chassis – BR Grampus <i>For unfitted Grampus. Underframe and body detailing. Includes the distinctive baskets used to hold the removable ends.</i>	£17.50
<b>B.35</b>	RCH 21'6" x 12' Lifting Link Brake Chassis - GWR & SR Tunny <i>For use with the Chivers GWR and SR Tunny kits.</i>	£16

### Bachmann Grain Hoppers

3 kits to upgrade the Bachmann BR welded grain hopper model. Etched subframe and detailing. 3D printed solebars, brake shoes, hollow buffer housings, springs and axleboxes. If you have a preference for axlebox type, please state when ordering.

<b>B.36A</b>	Early Unfitted Bachmann Grain Hopper Chassis <i>For unfitted wagons with early type hopper release mechanism (vees each side - lot 2183 wagons only).</i>	£20
<b>B.36B</b>	Late Unfitted Bachmann Grain Hopper Chassis <i>For unfitted wagons with later type hopper release mechanism (pedestal on one side).</i>	£20
<b>B.36C</b>	Through Piped Bachmann Grain Hopper Chassis <i>For lot 3233 &amp; 3234 wagons.</i>	£20

## LMS/Derby/LNER Clasp Brake

Code	Description	Price per unit
<b>B.51</b>	BR 17'6" x 10' LMS Clasp Brake Chassis <i>For Vans, Opens, Shocopens, Conflats, etc</i>	£13.50
<b>B.52</b>	RCH 17'6" x 10' LMS Clasp Brake Chassis <i>For Vans, Opens, Conflats, etc</i>	£13.50
<b>B.53</b>	BR 17'6" x 10' Derby Clasp Brake Chassis <i>For lot 3082 and 3232 Shocopens and the Vanwides</i>	£13.50
<b>B.54</b>	BR 32' x 18'6" BR Clasp Brake Tube Chassis <i>For clasp brake diagram 1/448 Tubes</i>	£17.50
<b>B.61</b>	BR 17'6" x 10' LNER Clasp Brake Chassis <i>For Vans, Shocvans, Opens, Lowfits, etc</i>	£13.50

## Tank Wagon Underframes

<b>B.71</b>	BR 17'6" x 10' Independent Brake Chassis - 14T Anchor Tanks <i>For the Bachmann anchor mount tank wagon. Includes ladders and valve wheel for detailing the body.</i>	£17.50
<b>B.72</b>	Additional Parts for 14T Anchor Mount Chassis - RCH axleguards <i>Replacement parts for B.71 for early 14T wagons - Requires B.71</i>	Withdrawn
<b>B.73</b>	Additional Parts for 20T Anchor Mount Chassis - BR Plate axleguards <i>Replacement parts for B.71 for later 20T wagons - Requires B.71</i>	Withdrawn
<b>B.74</b>	Additional Parts for 20T Anchor Mount Chassis - BR Plate axleguards <i>Replacement parts for B.71 for early 20T wagons - Requires B.71</i>	Withdrawn
<b>B.75</b>	RCH 17'6" x 10' Independent Brake Chassis (1927 underframe) <i>For saddle and cradle mounted tank wagons built after 1927. Can be used with the Bachmann cradle mounted tank wagon.</i>	£17.50
<b>B.75</b>	RCH 17'6" x 10' Independent brake Chassis (1927 underframe) <i>For saddle and cradle mounted tank wagons built shortly after 1927 (9' wheelbase wagons were generally only built for a few years after 1927). Can be used with the Bachmann cradle mounted tank wagon.</i>	£17.50

## Wagon Detailing Parts

Additional components for use with Rumney Models wagon chassis

<b>B.91</b>	Brackets and Covers for Shock Absorbing Wagons <i>Provides brackets and covers for the distinctive shock absorbing gear used on opens and vans. GWR and LMS/BR variations are covered. Requires 8BA or M2 bolt thread for the springs.</i>	£3
<b>B.92</b>	Tarpaulin Bar Detailing <i>For BR/LMS open wagons with corrugated steel ends. Both early and late types are included. Sufficient parts for two wagons. Wire for the bar is required.</i>	£3.50
<b>B.93A</b>	Buffer springing mechanism - 9" solebar <i>Provides guitar wire leaf springing for buffers. Suitable for Rumney Models underframes with 9" solebars. Sufficient for 6 wagons and includes parts for shock absorbing wagons.</i>	£5
<b>B.93B</b>	Buffer springing mechanism - 10" solebar <i>Provides guitar wire leaf springing for buffers. Suitable for Rumney Models underframes with 10" solebars. Sufficient for 5 wagons.</i>	£3.50
<b>B.94</b>	Wagon Coupling hooks <i>Sufficient for 7 wagons.</i>	£2
<b>B.95A</b>	BR Instanter links <i>Sufficient for 7 wagons.</i>	£1.50
<b>B.96</b>	Screw couplings <i>Sufficient for 2 wagons.</i>	£2.50

<b>Code</b>	<b>Description</b>	<b>Price per unit</b>
<b>B.101</b>	LNER/BR Steel Open Detailing <i>Etched end stanchions to replace those on the end of Parkside bodies. Two profiles covering LNER and BR builds. Label boards and LNE style lamp irons also included. Sufficient parts for 3 wagons.</i>	£3
<b>B.102</b>	LMS Corrugated Steel Ended Wooden Open Detailing <i>Body side capping and strapping, lamp irons and label boards.</i>	£2
<b>B.103</b>	BR Corrugated Steel Ended Wooden Open Detailing <i>Body side capping, lamp irons and label boards.</i>	£1.50
<b>B.104</b>	BR Corrugated Steel Ended Wooden Shocopen Detailing <i>Body side capping and strapping, lamp irons, label boards and cleats as well as the body side part of the corrugated end.</i>	£2.50
<b>B.105</b>	Ratio LMS Van Detailing <i>Diagonal side strapping as fitted in BR days, lamp irons, label boards.</i>	£1
<b>B.106</b>	Bachmann Anchor Mount Tank Wagon Detailing Two sets of different ladders, brake levers, brake lever guards, tie bars and valve wheel. Sufficient parts for 2 wagons.	£5
<b>B.107</b>	BR 13T China Clay Open Detailing Etched end stanchions to replace those on the end of Ratio bodies. Lamp irons also included. Sufficient parts for 6 wagons.	£3.50
<b>B.108</b>	General Wagon Detailing Lots of little bit for detailing up plastic kits and RTR models. Includes solebar detailing (number plates, label clips, etc), label boards and lamp irons. Sufficient bits for 3 or 4 wagons.	£3.50
<b>B.109</b>	BR Grampus detailing A pair of baskets, door springs and end steps for detailing the Parkside kit.	£4
<b>B.112</b>	Backing Plates for Heavy Duty Axleboxes For use with Rumney Models HD axlebox and spring castings when fitting to other manufacturer's underframes. Sufficient for three wagons.	£0.50
<b>B.113</b>	Bachmann Saddle Mounted Tank Wagon Detailing Two sets of different ladders, brake levers, brake lever guards, tie bars, valve wheel, tank straps and outside solebar crosshead tie down brackets. Sufficient parts for 2 wagons.	£7
<b>B.114</b>	Morton 10ft Wagon Detailing A detailing fret for use with Bachmann and Parkside, etc wagons. Includes open wagon door springs, vees, GWR and RCH brake lever guards and brake levers, plus detailing. Sufficient parts for 2 wagons.	£5.50

## Wagon Kits

### BR Strip Coils

BR built two batches of steel bogie open wagons for carrying steel coil 'eye to the sky' in South Wales. The kits cover the original wood lined wagons and the wagons after the lining was removed and both unfitted and vacuum braked versions of the unlined wagons. Bogies are included. Vacuum cylinders (F.02 - 21") are available from Rumney Models for fitted wagons. Buffers will be needed.

Code	Description	Price per unit
<b>C.01A</b>	BR 42T Strip Coil Wagon <i>Diagram 1/407 steel coil wagons. Covers the lot 2209 South Wales Strip Coils from 1955 onwards. Includes GWR HD bogies PG.05.</i>	£41
<b>C.01B</b>	BR 42T Strip Coil Wagon <i>Diagram 1/403 steel coil wagons. Covers the lot 3104 South Wales Strip Coils. Includes BR HD bogies PG.06.</i>	£41
<b>C.02</b>	BR 42T Strip Coil Wagon - Wood Lined <i>Diagram 1/401 steel coil wagons. Covers the lot 2209 South Wales Strip Coils up to 1955. Includes GWR HD bogies PG.05.</i>	£41

### Bogie Bolsters

A series of kits to upgrade the Bachmann Bogie Bolster C/Macaw B and the Lima Bogie Bolster E. Some are simple brakegear and detailing frets whilst others allow replacement trussing to be built. All kits are etch only. For those wishing to further upgrade their Bogie Bolster Cs/Macaw Bs, suitable freight bogies are available from Rumney Models (see section G, page 16)

<b>C.04</b>	BR 32T Bogie Bolster E Detailing <i>An "upgrade" etch for the Lima Bogie Bolster E model. Includes full brakegear, etched 'queen posts', trussing jigs and solebar/headstock detailing. Brass angle for the trussing is required.</i>	£5
<b>C.04A</b>	BR 32T Bogie Bolster E Underframe <i>For use with C.04 to produce a fully etched chassis. Includes solebars, headstocks and detailing.</i>	£9
<b>C.05</b>	BR Bogie Bolster C/GWR Macaw B Detailing <i>An "upgrade" etch for the Bachmann/Mainline BBC/Macaw B model. Includes full brakegear (with options for GWR D/C, unfitted lever brake and fitted lever brake types), etched 'queen posts' and trussing jigs and solebar/headstock detailing. Brass angle for the trussing is required.</i>	£13
<b>C.05A</b>	BR Bogie Bolster C/GWR Macaw B Levers & Veas - Lever Brakegear Proper lever brakegear and detailing parts for the Bachmann/Mainline BBC/Macaw B models. This etch does not include anything to replace the trussing on the model. Includes sufficient parts for 2 wagons with options for either 1 x fitted and 1 x unfitted or 2 x unfitted wagons.	£10
<b>C.05B</b>	BR Bogie Bolster C/GWR Macaw B Levers & Veas - D/C Brakegear Proper D/C brakegear and detailing parts for the Bachmann/Mainline Macaw B models. This etch does not include anything to replace the trussing on the model. Includes sufficient parts for 2 wagons.	£7



#### 4 Wheel Plate Wagons

4 kits covering the 22T plate wagons built by the LMS, LNER and BR. All variations in body construction (all riveted, all welded or welded sides and riveted ends/3 or 4 hinges per door) are covered along with RCH unfitted lifting link and two types of BR clasp vacuum brakegear. The kits are etch and spring wire only. Suitable springs/axleboxes and vacuum cylinders (F.02 - 21") are available from Rumney Models. Will need buffers.

Code	Description	Price per unit
<b>C.21A</b>	22T Plate Wagon with Welded Body – BR Clasp Brake Chassis (new builds) <i>BR diagram 1/434 Plate wagons built new with the BR clasp brake. Body and chassis kit B.08.</i>	£32
<b>C.21B</b>	22T Plate Wagon with Welded Sides and Riveted Ends – BR Clasp Brake Chassis (retrofits) <i>BR diagram 1/430 and 1/431 Plate wagons retrofitted with the BR clasp brake in the late 50s/early 60s. Body and chassis kit B.09.</i>	£32
<b>C.21C</b>	22T Plate Wagon with Welded Sides – Lifting Link Brake Chassis <i>LMS, LNER and BR unfitted Plate wagons with welded sides. Includes both welded and riveted ends. Body and chassis kit B.27.</i>	£32
<b>C.22</b>	22T Plate Wagon with Riveted Body – Lifting Link Brake Chassis <i>LMS &amp; LNER unfitted Plate wagons with fully riveted bodies. Body and chassis kit B.27.</i>	£32

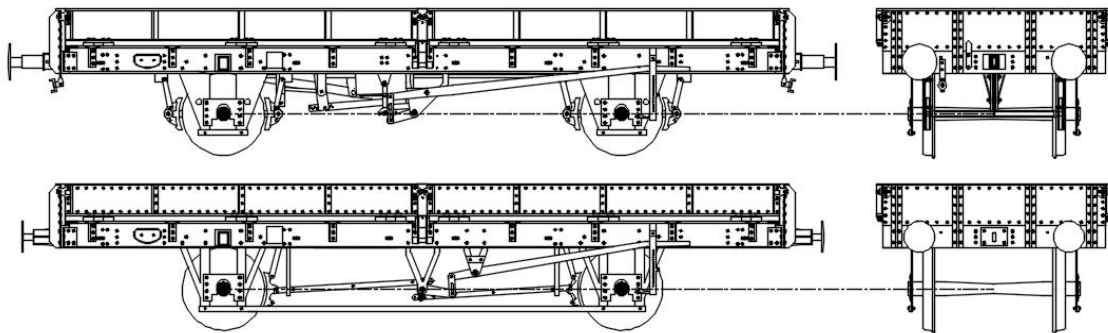

#### GWR Herring

A complete kit for the diminutive and distinctive Great Western ballast hopper.

<b>X.11</b>	GWR P22 20T "Herring" Ballast Hopper <i>Etched body and sprung chassis. Includes castings for buffers, springs/axleboxes, vacuum cylinder and vacuum pipes.</i>	£39
-------------	--	-----

#### BR 1/801 Fish Van

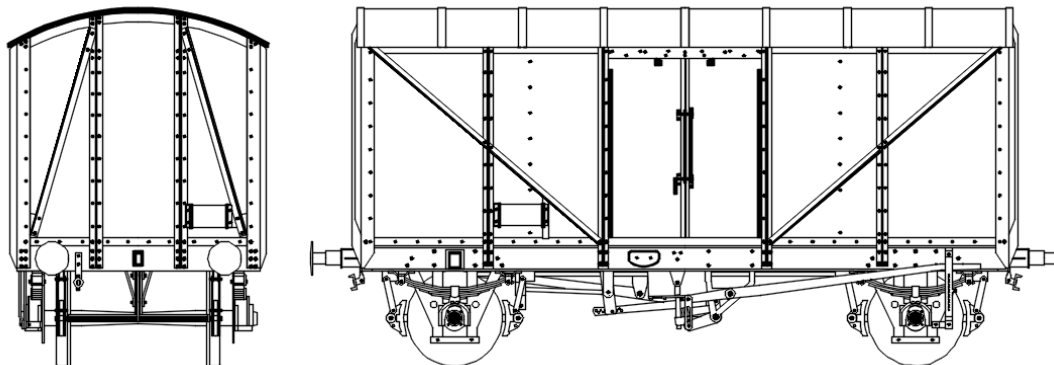

The final BR fish van diagram built 1957-60 with the BR clasp brake. Many were later used as parcels vans (SPV).

Code	Description	Price per unit
<b>C.51</b>	BR 1/801 12T Fish Van <i>Etched chassis and body with a 3D printed roof, springs/axleboxes and a whitemetal vacuum cylinder.</i>	£49

### General Merchandise Open Wagon Conversions

These conversions are designed to be used with Parkside PC.02A sides (not included) to create wooden ended versions of the BR/LMS steel ended 5 plank open/shocopen.

<b>C.53</b>	LMS D.1892 5 Plank Open Wagon Body 'Kit' <i>Etched ends, floor and ironwork. Suitable chassis: B.12 &amp; B.52.</i>	£13
<b>C.53A</b>	LMS D.1892 5 Plank Open Wagon Body 'Kit' – Steel Reinforced Ends Etched ends, floor and ironwork. For wagons where the lower end planks were replaced with steel channel. Suitable chassis: B.12 & B.52.	£13
<b>C.54</b>	BR 1/040 Wooden Ended Shocopen Wagon Body 'Kit' Etched ends, floor and ironwork only for use with Parkside Dundas PC02A or PC28 sides (not included). Due to steel shortages in 1952 half a lot of BR Shocopens were built with wooden rather than steel corrugated ends. Includes tarpaulin bar kit B.92. Suitable chassis: B.11 (would also require shock absorbing spring etch B.91).	£13

### LMS/LNE/BR Gunpowder Vans

The kits are a mixed media affair, mainly in 3D printed resin (body, solebars, buffer housings, springs/axleboxes and brakegear) but with a sprung brass 'under frame', roof (for a prototypically thin look) and detailing parts along with a cast whitemetal vacuum cylinder (where appropriate). All variations in the LMS/LNE/BR Gunpowder vans with push rod brakegear are covered. Suitable axleboxes and buffer housings will be included but if you require something specific, please state when ordering. The kits will be produced in small batches, please inquire for availability.

These kits need to be sent small parcel so are subject to £2 postal surcharge. The surcharge applies only once per order, no matter how many kits are ordered.

<b>PC.55A</b>	LMS/LNE Unfitted Gunpowder Van <i>Independent brakegear.</i>	£39
<b>PC.55B</b>	BR Unfitted Gunpowder Van <i>Morton 2 shoe brakegear.</i>	£39
<b>PC.55C</b>	BR 'New Build' Fitted Gunpowder Van <i>Morton 4 shoe vacuum brakegear. Vans built new by BR with vacuum brakes.</i>	£39
<b>PC.55D</b>	LMS/LNE Retrofitted Gunpowder Van - RCH axleguards Morton 4 shoe vacuum brakegear. LMS and LNE vans retrofitted by BR as part of the modernisation program.	£39
<b>PC.55E</b>	BR Retrofitted Gunpowder Van Morton 4 shoe vacuum brakegear. Early BR vans retrofitted by BR as part of the modernisation program.	£39
<b>PC.55F</b>	LMS/LNE Retrofitted Gunpowder Van - BR axleguards Morton 4 shoe vacuum brakegear. LMS and LNE vans retrofitted by BR as part of the modernisation program and fitted with replacement BR axleguards.	£39

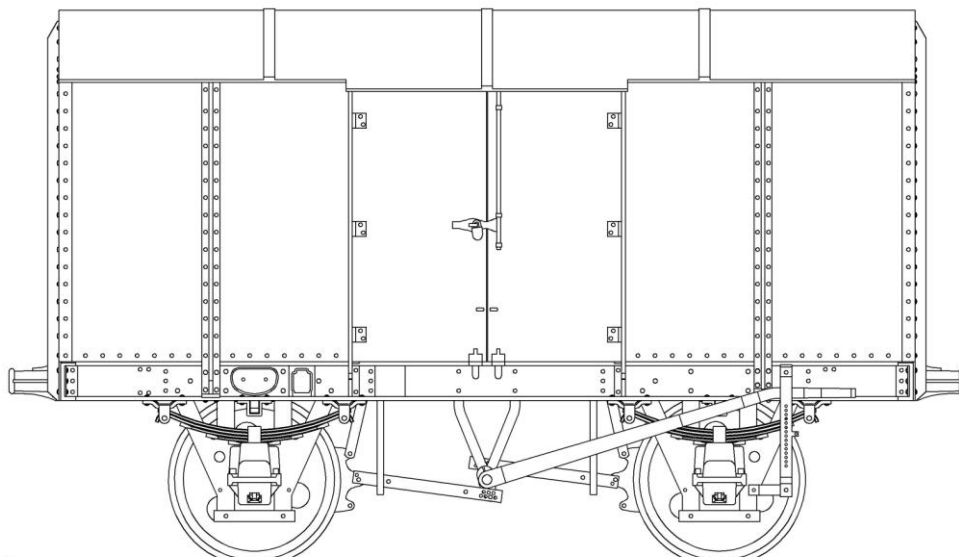

### BR 1/221 Izal Palvan

In 1960 BR built 250 specialist wagons for carrying palletised Izal products from their factory in Sheffield. The kit is another mixed media affair with a mixture of etched and 3D printed parts. The kits are supplied with the original pattern J-hanger springs and roller bearings. Some wagons were fitted with long 'standard' springs with no J-hangers late in life, these are available by request when ordering. Optional 3D printed solebars are available separately to use in place of the etched version included in the kit if required. Transfers are available from Cambridge Custom Transfers.

Code	Description	Price per unit
<b>PC.56</b>	BR 1/221 'Izal' Palvan Etched underframe, end framing and details. 3D resin printed sides, inner ends (with their distinctive chamfers), roof, Oleo buffer housings and springs/axleboxes. Includes a cast 18" whitemetal vacuum cylinder.	£48
<b>PC.56A</b>	3D printed solebars for use with the Izal Palvan kit	£3.50

### Tank Wagon Kits

Something a bit special and what could, depending on sales, be the first of a large range of late steam era oil and chemical tank wagons. Full kits for the 7'3" Air Ministry 14T Class A and Class B conversion tanks. The kits include an underframe, tank and details etched in two materials and on three different thicknesses along with 3D printed saddles, tank ends, one piece end stanchions/crossbeams, springs/axleboxes, buffer housings and tank fittings. There is a choice of riveted or welded tanks and both versions are offered with either Class A or Class B fittings. There is also a choice of the original small walkways or the 4 support type fitted by SMBP from the late fifties. Esso and SMBP style ladders are also included. EM and P4 only.

<b>PC.111RA</b>	7'3" 14T Air Ministry Oil Tank Wagon <i>Riveted tank, class A fittings.</i>	£48
<b>PC.111RB</b>	7'3" 14T Air Ministry Oil Tank Wagon <i>Riveted tank, class B conversion fittings.</i>	£48
<b>PC.111WA</b>	7'3" 14T Air Ministry Oil Tank Wagon <i>Welded tank, class A fittings.</i>	£48
<b>PC.111WB</b>	7'3" 14T Air Ministry Oil Tank Wagon <i>Welded tank, class B conversion fittings.</i>	£48

## Lima Bogie Vee Presflo Detailing

Code	Description	Price per unit
<b>X.33A</b>	Lima Bogie Vee Presflo Skirts and Detailing A set of etches and 3D prints to update and correct the Lima model. The etched skirts are correct length with 3D printed ends. You will need to lengthen the outer ends of the tanks with plastic strip (not included). The etched detailing includes new walkways, ladders, end anchors and lifting brackets as well as lamp irons, brake wheels and solebar detailing. 3D printed manholes are also included.	£24
<b>X.33B</b>	Lima Bogie Vee Presflo Detailing Only As per the 'full' kit above but without the skirts. The etched detailing includes new walkways, ladders, end anchors and lifting brackets as well as lamp irons, brake wheels and solebar detailing. 3D printed manholes are also included.	£8

## Wagon Castings

### Vacuum Cylinders

<b>F.01</b>	18" Wagon Vacuum Cylinders and Brackets <i>Set of 3 whitemetal vacuum cylinders and etched brackets.</i>	£6
<b>F.02</b>	21" Wagon Vacuum Cylinders and Brackets <i>Set of 3 whitemetal vacuum cylinders and etched brackets.</i>	£6
<b>F.02A</b>	21" Hopper Wagon Vacuum Cylinder and Brackets <i>Set of 1 whitemetal vacuum cylinder and etched brackets for hopper wagons.</i>	£2
<b>F.03A</b>	Bogie Bolster C late type bolsters (diagram 1/474 & 1/477) <i>Set of four whitemetal bolsters and etched detailing parts.</i>	£6.50
<b>F.03B</b>	Bogie Bolster C late type bolsters (diagram 1/475) <i>Set of four whitemetal bolsters and etched detailing parts.</i>	£6.50

### Late type Bogie Bolster C Bolsters

<b>F.03A</b>	Bogie Bolster C late type bolsters (diagram 1/474 & 1/477) <i>Set of four whitemetal bolsters and etched detailing parts.</i>	£6.50
<b>F.03B</b>	Bogie Bolster C late type bolsters (diagram 1/475) <i>Set of four whitemetal bolsters and etched detailing parts.</i>	£6.50

The difference between F.03A and F.03B lies in the centre pair of bolsters. On diagram 1/475 wagons these were fixed meaning the ends of the bolsters were slightly different. F.03A consists of four Type A bolsters and F.03B consists of 2 Type A bolsters and 2 type B bolsters.

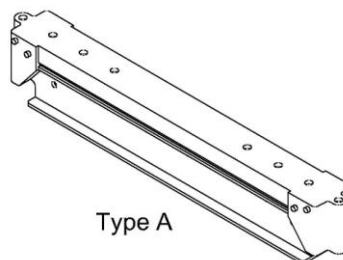

Type A

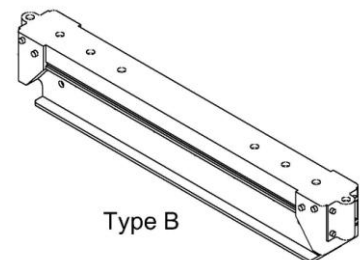

Type B



## Standard Wagon Axleboxes and Springs

Code	Description	Price per unit
<b>Various</b>	Set of four whitmetal axleboxes and springs	£3.50

### Notes:

Oil axleboxes come with the axlebox attached to the spring and are slotted for use with sprung underframes. **FA-FD & FM** are based on prototypes with 9" x 4½" journals and are for wagons of 12T to 16T capacity. **FN-FS** are based on prototypes with 10" x 5" journals and are for wagons of 20T to 22T capacity (heavy duty - HD). If you are using the HD axleboxes (**FN-FS**) on wagons produced by other manufacturers you will need backing plates (**B.112**) for the reinforced axlebox guides riveted to the axleguards. You do not need them for Rumney Models kits. Roller bearing axleboxes come with both a hooded and non-hooded type. These are separate from the spring and are designed to be attached to the bearing in the spring carrier on my suspension system except for the BR brake van ones where the bearing is attached to the spring.

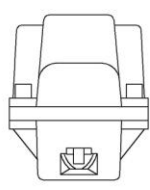
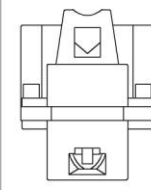
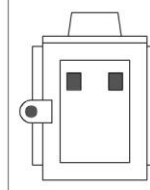
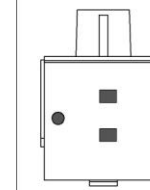
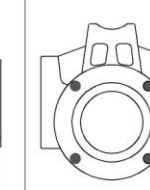
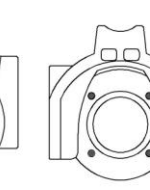
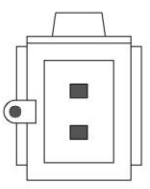
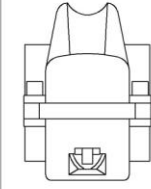
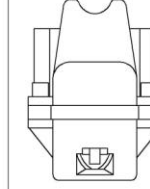
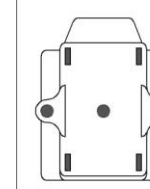
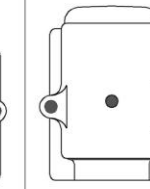
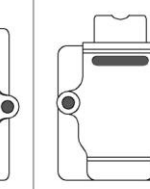
Axleboxes types currently available:

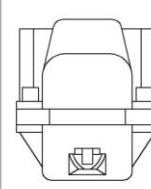
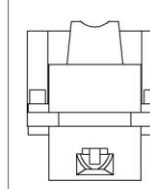
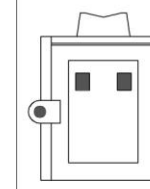
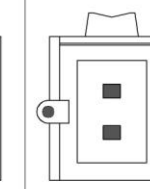
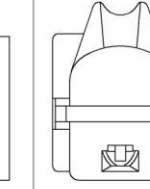
					
<b>FA</b> BR 2 Part	<b>FB</b> BR 2 Part Square	<b>FC</b> BR Welded Horizontal Lugs	<b>FD</b> BR Platefront	<b>FE</b> Roller Bearing Non-hooded & Hooded	
					
<b>FF</b> BR Welded Vertical Lugs	<b>FG</b> RCH 2 Part	<b>FH</b> LMS 2 Part	<b>FJ</b> LMS Platefront Vertical Front	<b>FK</b> LMS Platefront Sloping Front	<b>FL</b> LNER Cast
					
<b>FM</b> LNER Welded	<b>FN</b> BR 2 Part HD	<b>FO</b> BR 2 Part Square HD	<b>FP</b> BR Welded HD Horizontal Lugs	<b>FQ</b> BR Welded HD Vertical Lugs	<b>FS</b> RCH 2 Part HD

The following table shows the combinations available. The code is given by two parts. The first part is the axlebox reference and the second the spring type.

The springs are arranged by the number of leaves so **05** is a 5 leaf springs, **06** is a 6 leaf spring, etc.

**07LM** refers to the LMS 7 leaf springs with J hangers that were found on general merchandise wagons fitted with their clasp braking system (Rumney Models underframes B.51 and B.52).

**07BR** are BR 20T brake van springs with their own distinctive J hangers and are ideal for Dave Bradwell's underframes.

	05	06	07LM	07BR	07	08	09
<b>FA</b> - BR 2 Part	•	•	•	•			
<b>FB</b> - BR 2 Part Square	•	•	•				
<b>FC</b> - BR Welded - Horizontal Lugs	•	•	•				
<b>FD</b> - BR Platefront	•	•	•	•			
<b>FE</b> - Roller Bearings	•	•		•	•	•	•
<b>FF</b> - BR Welded - Vertical Lugs	•						
<b>FG</b> - RCH 2 Part	•	•					
<b>FH</b> - LMS 2 Part	•		•				
<b>FJ</b> - LMS Platefront - Vertical Front	•		•				
<b>FK</b> - LMS Platefront - Sloping Front	•	•	•				
<b>FL</b> - LNER Cast	•		•				
<b>FM</b> - LNER Welded	•	•		•			
<b>FN</b> - BR 2 Part HD					•	•	
<b>FO</b> - BR 2 Part Square HD					•		
<b>FP</b> - BR Welded HD - Horizontal Lugs					•	•	
<b>FQ</b> - BR Welded HD - Vertical Lugs					•		
<b>FS</b> - RCH 2 Part Cast HD					•	•	

### What to order

So if you want a set of BR 2 part axleboxes with 6 leaf springs then use the code **FA.06**.

If you want a set of BR Platefront axleboxes with 7 leaf LMS springs then use the code **FD.07LM**.

If you want a set of roller bearing axleboxes and 8 leaf springs then use the code **FE.08**.

Etc...

## Other Types of Cast Axleboxes and Springs

### Milk Tanks

Code	Description	Price per unit
<b>FA.08GWMILK</b>	GWR Milk Tank Springs and BR 2 Part Oil Axleboxes	£5.50
<b>FG.08GWMILK</b>	GWR Milk Tank Springs and RCH 2 Part Oil Axleboxes	£5.50
<b>FT.07LMMILK</b>	LMS Milk Tank Springs and Oil Axleboxes	£5.50

Milk tank springs and axleboxes come in sets of 6 with an etch for the reinforced axlebox guides on the outer axles. Note that the centre axles on GWR milk tanks fitted with oil journals were always RCH type it was just the outer axles that could change.

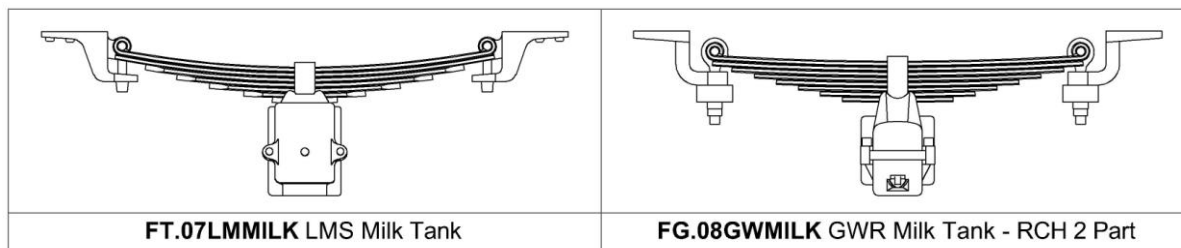

### Brake Vans

<b>FN.09GW</b>	GWR Brake Van Springs and BR 2 Part HD Oil Axleboxes	£3.50
<b>FS.09GW</b>	GWR Milk Tank Springs and RCH 2 Part HD Oil Axleboxes	£3.50
<b>FT.10LMST</b>	LMS Stanier Brake Van Springs Axleboxes	£3.50

GWR brake van springs are the later swing link type with 10" journals for diagrams AA.15 (last batch), AA.19, AA.20, AA.21, AA.23 - They will need backing plates B.112 for the reinforced axlebox guides.

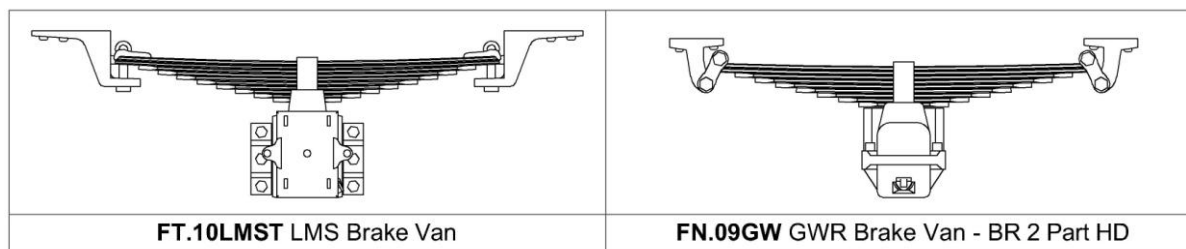

### 3D Printed Wagon Axleboxes and Springs

<b>Various</b>	Set of four 3D printed resin axleboxes and springs	£4
----------------	--	----

High quality resin 3D prints. Spring and axlebox are printed as one part and the axleboxes come slotted for sprung underframes. Please allow 2 weeks for delivery. If you are using the HD axleboxes (**PFR, PFT and PFV**) on wagons produced by other manufacturers you will need backing plates (**B.112**) for the reinforced axlebox guides riveted to the axleguards. You do not need them for Rumney Models kits.

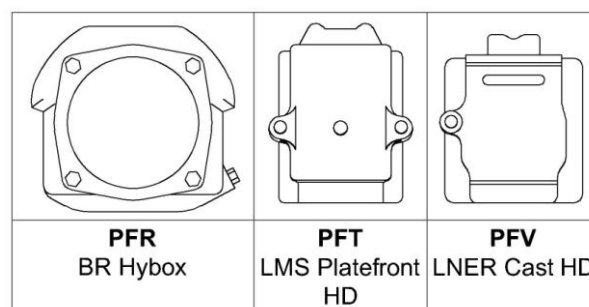

## Heavy Duty Axleboxes

**PFR** - BR Hyboxes with 7 leaf (**PFR.07** - Plates, Tubes, Grampus), 8 leaf (**PFR.08** - Iron Ore Tipplers) or 9 leaf springs (**PFR.09** - Iron Ore Hoppers)

**PFT**- LMS Sloping Platefront HD Axleboxes with 7 leaf springs (**PFT.07** - Iron Ore Hoppers; early Double Bolsters, Long Lows and Tubes)

**PFV** - LNER Cast HD Axleboxes with 7 leaf springs (**PFV.07** - 21T Hoppers, 21T Minerals, Plates, Tubes, Double Bolsters)

## 5 Leaf Springs for Wooden Solebars

The full range of Rumney Models 'light' axleboxes are now available with 5 leaf springs for wooden solebars (**.05W**). These have prototypically correct flat shoes and are designed to fit scale 12" deep wooden solebars.

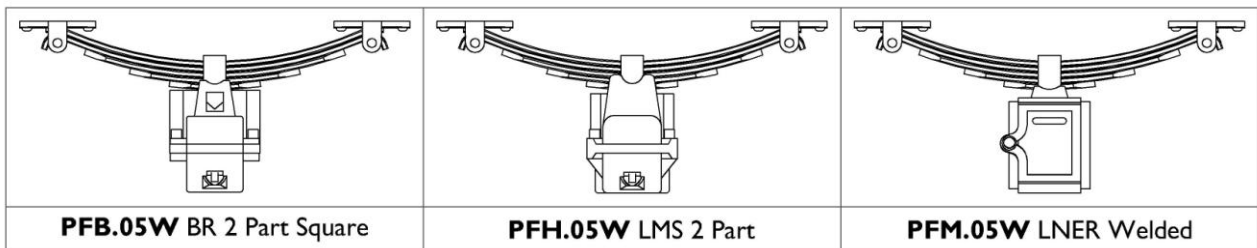

**.05W** - 5 leaf springs for wooden solebars. Available with axleboxes FA-FM.

**PFA.05W** - BR 2 Part

**PFB.05W** - BR 2 Part Square

**PFC.05W** - BR Welded

**PFD.05W** - BR Platefront

**PFG.05W** - RCH 2 Part

**PFH.05W** - LMS 2 Part

**PFJ.05W** - LMS Vertical Platefront

**PFK.05W** - LMS Sloping Platefront

**PFL.05W** - LNER Cast

**PFM.05W** - LNER Welded

## Specials

**PFZ.BRCCT** - BR CCT

**.06PAL** - Springs for BR Palvans. Available with BR axleboxes FA-FE. (e.g. PFC.06PAL)

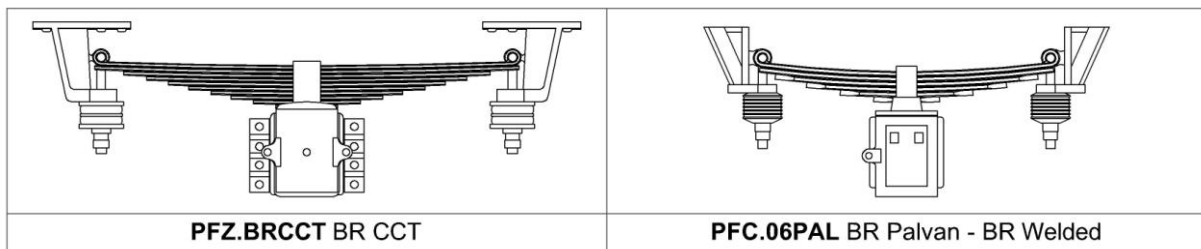



**Continental Style Fittings**

**PFE(cov).08UICFO** - BR Ferry Opens to diagram 1/055 with covered roller bearings

**PFE.08UICFV** - BR Ferry Vans to diagram 1/227

**PFE(cov).08UICFO** - BR Ferry Opens to diagram 1/055 with oil axleboxes

**PFZ.09MOTHOP** - MOT/LNE 167 21T Hoppers. Include the distinctive coupling pockets.

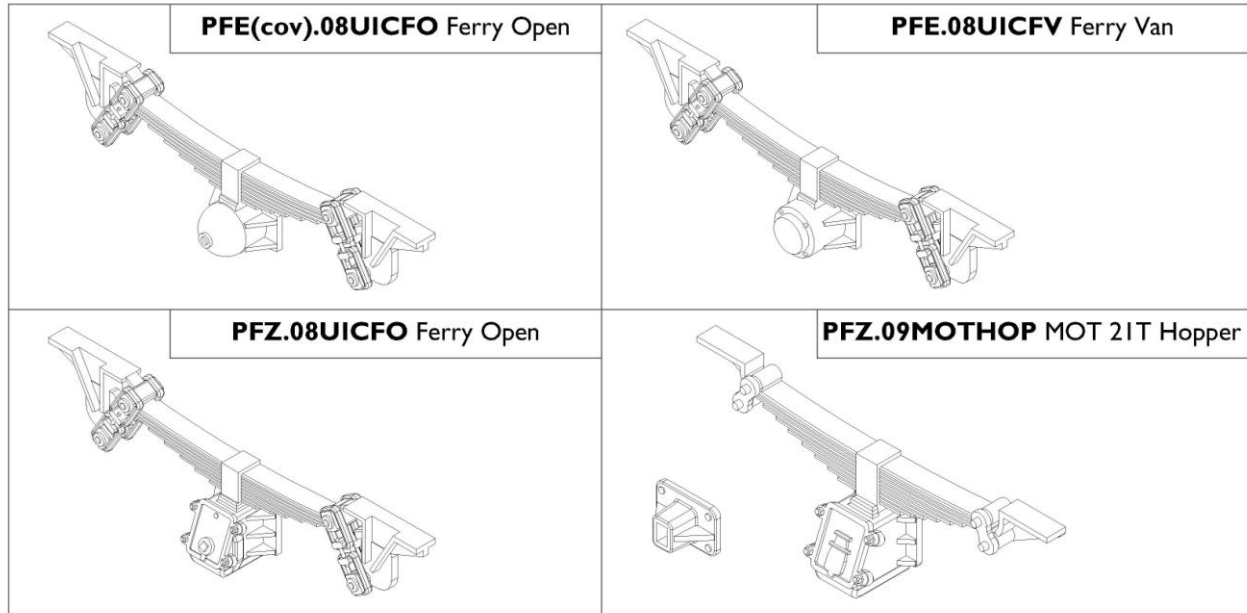

**Sprung Freight Bogies**

Sprung 5'6" freight bogies. 3D printed cosmetic sideframes with a sprung etched frame. Etch, spring wire and 3D prints included. Price is for a pair of bogies.

**BR 5' 6" Plate Freight Bogies**

**PG.01** Oil Bearings

**PG.02** Roller Bearings

**PG.06** Heavy Duty

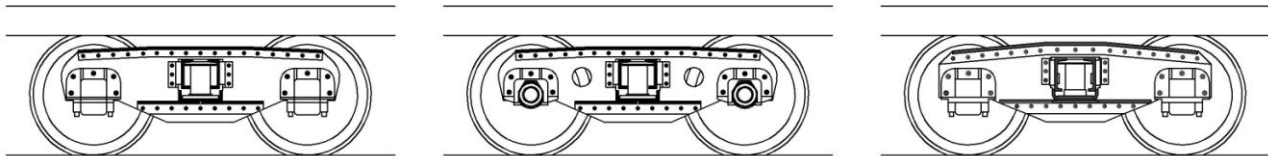

**GWR 5' 6" Plate Freight Bogies**

**PG.03A** Lightweight

**PG.03B** Lightweight

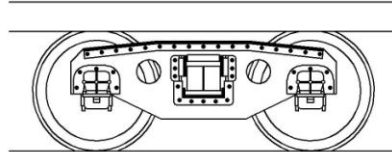
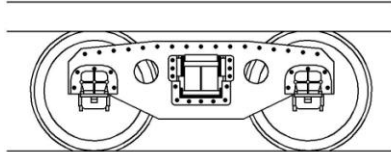

**PG.04** Standard

**PG.05** Heavy Duty

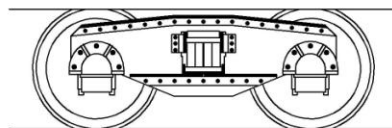
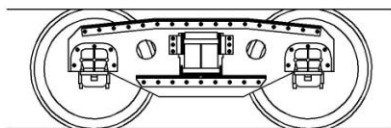

Code	Description	Price per unit
<b>PG.01</b>	BR 5'6" Plate Freight Bogie - Oil Journals <i>Standard design with oil journals.</i>	£14
<b>PG.02</b>	GWR 5'6" Plate Freight Bogie - Roller Bearing Journals <i>Standard Design with roller bearings.</i>	£14
<b>PG.03A</b>	GWR 5'6" Plate Freight Bogie - Early Lightweight <i>Lightweight design without outside angle at the top of sideframe.</i>	£14
<b>PG.03B</b>	GWR 5'6" Plate Freight Bogie - Later Lightweight <i>Lightweight design with outside angle at the top of sideframe.</i>	£14
<b>PG.04</b>	GWR 5'6" Plate Freight Bogie - Standard <i>Standard design also found under early BR built stock.</i>	£14
<b>PG.05</b>	GWR 5'6" Plate Freight Bogie - Heavy Duty <i>Heavy duty design with distinctive scallop shell journals.</i>	£14
<b>PG.06</b>	BR 5'6" Plate Freight Bogie - Heavy Duty <i>BR version of the GWR Heavy Duty Bogie for the second batch of Strip Coils and WR Weltröls.</i>	£14
<b>PG.11</b>	LNER 5'6" Diamond Freight Bogie - 50T <i>Heavy duty diamond bogie for the Sulphate and Brick wagons.</i>	£14

### Fully Sprung Diesel Bogies

An aid to producing a fully sprung diesel locomotive. P4 only unless indicated. Includes etch, spring wire and custom hornblocks. Each kit is sufficient for one locomotive.

<b>D.03</b>	Peak Pony Trucks - P4 <i>Pair of pony trucks to fit the Bachmann Peak chassis.</i>	£7
<b>D.03A</b>	Peak Pony Trucks - <u>EM Gauge</u> <i>Pair of pony trucks to fit the Bachmann Peak chassis.</i>	£7
<b>X.02</b>	Class 30/31 bogies <i>For the all wheel drive Hornby model.</i>	£38

### Fully Sprung Single Bolster Coach Bogie Subframes

Coach bogie subframes that work like the real thing. Etch, spring wire and bearing pins included. EM/P4 only. Price is for a pair of bogies. Require cosmetic sideframes.

<b>E.01</b>	8'6" BR Mk1 BR1	£15
<b>E.02</b>	8'6" BR Mk1 Commonwealth	£15
<b>E.04</b>	9' GWR Pressed Steel	£17
<b>E.05</b>	9' GWR Heavy Duty	£17
<b>E.06</b>	7' GWR	£15
<b>E.07</b>	8'6" LNER Gresley Standard	£17

### Coach Bogie Kits

Complete coach bogie kits. A further development of the subframes to include etched sideframes and bolsters along with castings for the springs/axleboxes & bolster springs. Etch, spring wire, bearing pins and castings or 3D prints included. EM/P4 only. Price is for a pair of bogies.

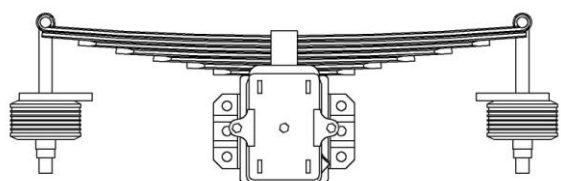
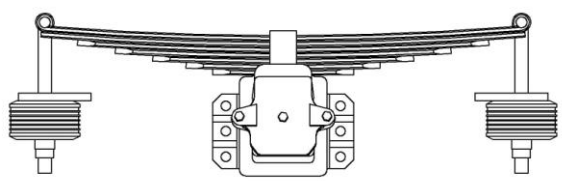
	
<b>E.110A</b> LMS Riveted Coach Bogie - Later Axlebox	<b>E.110B</b> LMS Riveted Coach Bogie - Early Axlebox

Code	Description	Price per unit
<b>E.101</b>	8'6" BR Coach Bogie (for Mk1 stock) <i>For EM and P4 only. Single bolster, original and revised light double bolster bogies. Includes provision to model riveted or welded bogies along with a choice of welded or riveted spring stops.</i>	£29
<b>E.110A</b>	9' LMS Riveted Coach Bogie (vertical Platefront axleboxes) <i>For EM and P4 only. A complete kit for the LMS riveted coach bogie. Includes provision different stepboards, correctly modelled ends for dynamo and non-dynamo bogies and 3D printed springs/axleboxes and bolster detail. Later vertical Platefront axleboxes.</i>	£27
<b>E.110B</b>	9' LMS Riveted Coach Bogie (sloping Platefront axleboxes) <i>For EM and P4 only. A complete kit for the LMS riveted coach bogie. Includes provision different stepboards, correctly modelled ends for dynamo and non-dynamo bogies and 3D printed springs/axleboxes and bolster detail. Earlier sloping Platefront axleboxes.</i>	£27

### Steam Loco Chassis/Detailing

Code	Description	Price per unit
<b>X.01</b>	GER/LNER/BR F4/5/6 2-4-2T <i>For EM and P4 only. A modern fold up nickel silver chassis to suit the Alan Gibson kit. Features built in CSB suspension along with brakegear, cosmetic driving wheel springs, ashpan detailing, guard irons, balance weights and 'phony trucks' to enable the loco to traverse curves down to 1m radius.</i>	£32
<b>X.04A</b>	MR/LMS/BR 1P 0-4-4T - Craftsman Version <i>For EM, P4 and OO. A modern sprung chassis to suit the Craftsman LMS 1P kit. Features sprung driving wheels, a sprung bogie, full brakegear, dummy inside motion, cast bogie details and a removable keeper plate with cosmetic driving wheel springs.</i>	£41
<b>X.04B</b>	MR/LMS/BR 1P 0-4-4T - Bachmann Version <i>For EM and P4. A replacement sprung chassis for the Bachmann LMS 1P. Features sprung driving wheels, a sprung bogie, full brakegear, dummy inside motion and a removable keeper plate with cosmetic driving wheel springs. Also includes 3D printed bogie details, sandboxes, brake cylinder and boiler bottom.</i>	£44
<b>X.07</b>	GER Y14 / LNER J15 0-6-0 <i>For EM, P4 only. A modern fold up nickel silver chassis to suit the Alan Gibson kit. Features built in CSB suspension along with brakegear, cosmetic driving wheel springs, ashpan detailing, guard irons and dummy inside motion. Covers variations in firebox type, steam and Westinghouse brakegear and contains parts to model the original Sharp Stewart engines.</i>	£38
<b>X.08</b>	GER S23 Tender Subframe <i>For EM, P4 only. A modern, fold up CSB, nickel silver chassis subframe to suit the Alan Gibson kit. Includes parts for both steam and Westinghouse brakegear along with replacement sideframes of the correct pattern.</i>	£13
<b>X.09</b>	GER Z14 Tender Subframe <i>For EM, P4 only. A modern, fold up, CSB, nickel silver chassis subframe for use with the Alan Gibson S23 kit. Covers all the main variation in both steam and Westinghouse brakegear along with replacement sideframes.</i>	£14

Code	Description	Price per unit
X.13	M&SWJR 2-4-0 Loco and Tender For EM, P4 and OO. A modern chassis for the NuCast Partners kit. Can be built rigid or sprung using High Level Hornblocks. A CSB setup is included for both the loco and tender to save the builder having to worry about it. Also included is full brakegear and a removable keeper plate with cosmetic driving wheel springs.	£35
X.15	Ivatt Pony Truck Detailing For use with the Brassmasters Ivatt pony truck kit. Enables the Brassmasters kit to be built as the swing link variety as fitted to one end of the Ivatt & BR 2-6-2T locos. As it comes the Brassmasters pony truck is for the spring controlled version.	£2
X.16	Bachmann SR N Class Loco chassis and tender subframe For EM and P4 only. Features independently sprung driving wheels, a sprung pony truck, valve gear, brakegear and a removable keeper plate with cosmetic driving wheel springs. Includes a CSB sprung tender subframe with full brakegear and is suitable for both the 3500 and 4000 gallon tenders.	£62
X.16A	Bachmann SR N Class tender subframe only <i>For EM and P4 only. A separate tender subframe from the Bachmann N Class loco kit. Features CSB suspension with full brakegear. Suitable for both the 3500 and 4000 gallon tenders.</i>	£14
X.21	BR/Ivatt Class 2 Detailing <i>Various detailing parts designed by Dave Holt for his own loco projects. Intended for the tank locos but some parts are also applicable to the tender versions. Includes balance weights, cab doors, injector parts, vacuum diaphragm brackets, tank straps, lamp irons, lubricator drive and buffer beam gussets.</i>	£8.50
X.22	Ivatt Class 2 Tank Bunker Ladder <i>An etched replacement bunker ladder designed by Pete Tarver for the Bachmann tank loco.</i>	£1.50
X.29	LMS 6'6" Trailing Bogie <i>A sprung bogie originally intended for a model of the LMS 2P but with applications for other LMS locos such as the 2-6-4Ts. P4 only.</i>	£6

### Miscellaneous

X.03	CSB Carrier Tags for Brassmasters Hornblocks <i>Two sets of 6 CSB carrier tags with 2 different hole sizes for use with Brassmasters hornblocks.</i>	£2
X.14	Stones Ventilators <i>A fret for the distinctive ventilators as fitted to late Midland and LMS period 1 and 2 coaching stock. The fret consists of 42 x 9 pane ventilators, 12 x 6 pane and 10 x 5 pane.</i>	£3

## 7mm Scale

The Milk Tank detailing and coach bogies are redrawn and resized from the 4mm scale artwork and etched on 0.012" brass. The Milk Tank plates were drawn up from my original artwork not the 4mm version. In short these are not just straight enlargements.

### Milk Tank Detailing

Code	Description	Price per unit
OA.07	United Dairies SR/GWR Platforms <i>The distinctive platforms fitted to some United Dairies milk tanks.</i>	£12
OA.08	SR/GWR Platform construction jig <i>Needed to build A.07.</i>	£10

### Milk Tank Plates

OA.21A	United Dairies Ltd Milk Tank Plates - Type A <i>Company plates for United Dairies milk tanks.</i>	£3.50
OA.21B	United Dairies Ltd Milk Tank Plates - Type B <i>Company plates for United Dairies milk tanks.</i>	£3.50
OA.22	Unigate Creameries Milk Tank Plates <i>Company/number plates for Unigate milk tanks.</i>	£3.50
OA.23	Express Dairy Milk Tank Plates <i>Company/number plates for Express Dairy milk tanks.</i>	£3.50

The 7mm scale version follows the same numbering pattern as the 4mm ones.

The United Dairies plates were common in the 1950s but could also be seen through to the 1970s. Type A was much more common than type B. Unigate plates would be found on wagons post 1959. They have the wagon number on the plate, and I have done plates for most Unigate diagrams. Please enquire first if you are after plates for specific diagrams. If you aren't worried about diagrams, then please say so when ordering.



- United Dairies Type A



- United Dairies Type B



- Unigate Creameries



- Express Dairy

Express Dairy plates include both the company plate and the distinctive round number plate that was attached to the baulks at the tank ends. The numbers were Express Dairy's own fleet numbers and were generally grouped according to who built the milk tank. If you want something specific, then please inquire or else you will get a random number. Etched on 0.1mm stainless steel and supplied in pairs and painted.

## Wagon Detailing

Code	Description	Price per unit
<b>OB.92</b>	Tarpaulin Bar Detailing <i>For BR/LMS open wagons with corrugated steel ends. Both early and late types are included. Sufficient parts for two wagons. Wire for the bar is required.</i>	£12.50
<b>OB.109</b>	Grampus Detailing <i>A pair of detailed baskets, door springs and end steps.</i>	£9.50
<b>OB.110</b>	RCH 12' Lifting Link Brakegear Detailing <i>A general purpose detailing fret. Includes 12' brakegear, vees, brake levers, lifting links &amp; two types of lever guards. Also 21T hopper door handles &amp; end steps and mineral wagon door springs.</i>	£13.50
<b>OB.111</b>	21T Vacuum Braked Hopper Detailing <i>All the bits specific to the vacuum brakegear on 21T hoppers. Includes vacuum cylinder brackets, brake links and lamp irons.</i>	£2.50

## Gauge 1

### Milk Tank Plates

I have a small selection of milk tank plates available to suit the Slaters LMS d1994 kit. Details are as per the 7mm versions on the previous page. Unigate and Express Dairies numbers are suitable for the LMS d1994 only.

<b>OA.21A</b>	United Dairies Ltd Milk Tank Plates - Type A <i>Company plates for United Dairies milk tanks.</i>	£6
<b>OA.22</b>	Unigate Creameries Milk Tank Plates <i>Company/number plates for Unigate milk tanks.</i>	£6
<b>OA.23</b>	Express Dairy Milk Tank Plates <i>Company/number plates for Express Dairy milk tanks.</i>	£6

## S Scale

Redrawn and resized from the 4mm scale artwork and etched on 0.012" brass. These are not just straight enlargements. They are available to order only.

<b>SA.01</b>	GWR Standard 20'6" Milk Tank Components <i>A sheet of etches covering almost everything I have done for standard GWR milk tanks but on one sheet in S Scale. Includes a fully sprung chassis, solebars, headstocks, both D/C and lever brakegear, ladders and partial platforms, walkways and tank straps.</i>	Withdrawn
<b>SB.13</b>	BR 16'6" x 9' Morton Brake Chassis – 16T Welded Mineral <i>For the standard welded body, Morton brake 16T mineral wagons. Tailored to suit the Alan Gibson Whitmetal body.</i>	£14
<b>SB.16</b>	BR 16'6" x 9' Independent Brake Chassis – 16T Welded Mineral <i>For the standard welded body, Independent brake 16T mineral wagons. Tailored to suit the Alan Gibson Whitmetal body.</i>	£18
<b>SB.32</b>	RCH 17'6" x 9' Morton Brake Chassis <i>For LMS &amp; GWR vans, Conflats, opens, etc.</i>	£20.50

Code	Description	Price per unit
<b>SB.51</b>	17'6" x 10' LMS Clasp Brake Wagon Chassis <i>For Vans, Opens, Shocopens, Conflats, etc. Specification is as per the 4mm chassis and includes both RCH and BR type axleguards.</i>	£24
<b>SB.61</b>	17'6" x 10' LNE Clasp Brake Wagon Chassis <i>For Vans, Opens, Shocopens, Conflats, etc. Specification is as per the 4mm chassis (B.61) and includes both RCH and BR type axleguards.</i>	£24

